

Castor wheel
manufacturers

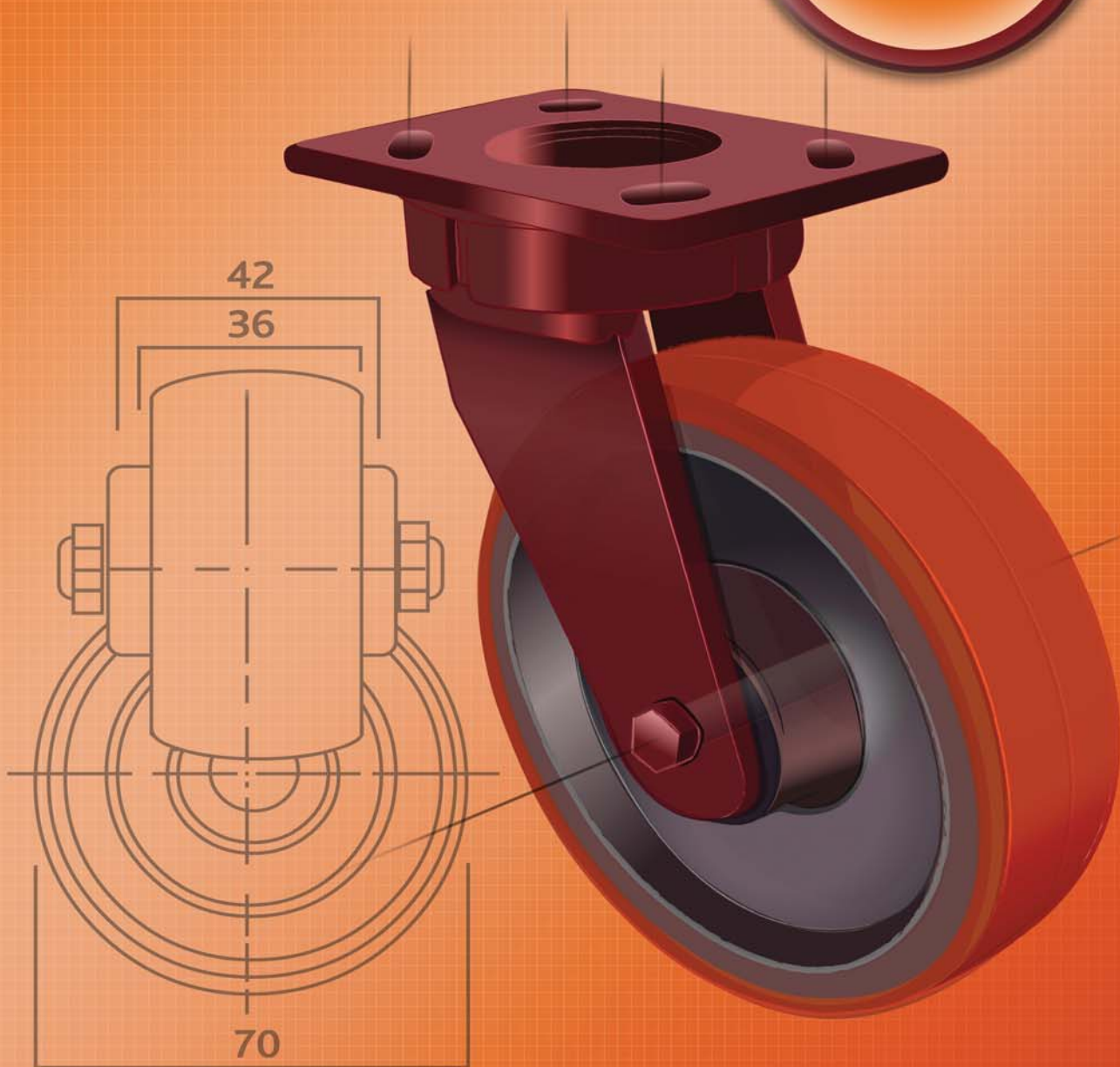

BAZROLL INTERNATIONAL LTD

Tel: 01249 822 222

www.bilgroup.eu



FITTINGS

Full range of axle accessories.

All bolts are 8.8 grade and nuts are of locking type.

Thread diameter (mm)	Tube diameter (mm)	Length (mm)	Depth (mm)	Bolt size used (mm)	Code
----------------------	--------------------	-------------	------------	---------------------	------

Axle diameter (mm)	Code
--------------------	------

BOLTS – 8.8 GRADE

8	-	50	-	-	BOLTM8X50Z8.8
		55	-	-	BOLTM8X55Z8.8*
		60	-	-	BOLTM8X60Z8.8*
10	-	50	-	-	BOLTM10X50Z8.8
		60	-	-	BOLTM10X60Z8.8
		65	-	-	BOLTM10X65Z8.8*
		70	-	-	BOLTM10X70Z8.8
12	-	80	-	-	BOLTM12X80Z8.8*
		90	-	-	BOLTM12X90Z8.8*

BI-LOC NUTS

8	-	-	-	-	NM8GR8Z
10	-	-	-	-	NM10GR8Z
12	-	-	-	-	NM12GR8Z

NYLOC NUTS

8	-	-	-	-	NM8NYZ*
10	-	-	-	-	NM10NYZ*
12	-	-	-	-	NM12NYZ*

TUBES

12	36	-	8	TUBEM12X36
	41.5	-	8	TUBEM12X40*
	42.4	-	8	TUBEM12X42
	46	-	8	TUBEM12X45*
14.9	51	-	10	TUBE9/16X50
15	46	-	10	TUBEM15X45*
	51	-	10	TUBEM15X50*
19.1	61.5	-	12	TUBE3/4
	61.5	-	12	TUBEM20X60*
	65	-	16	TUBEM20X65
20	91.5	-	14	TUBEM20X91

*Also available in stainless steel

WHEEL RETAINERS uncapped – dead end

12.70	WR0127
19.05	WR01905
20.00	WR020
25.00	WR025
25.40	WR0254



WHEEL RETAINERS capped – dead end

12.70	WRD127
19.05	WRD1905
20.00	WRD20
25.00	WRD25
25.40	WRD254



Buffer wheels fit on the tubular legs of trolleys to reduce damage to walls, revolving on contact and maintaining the trolley at a safe distance from the wall.

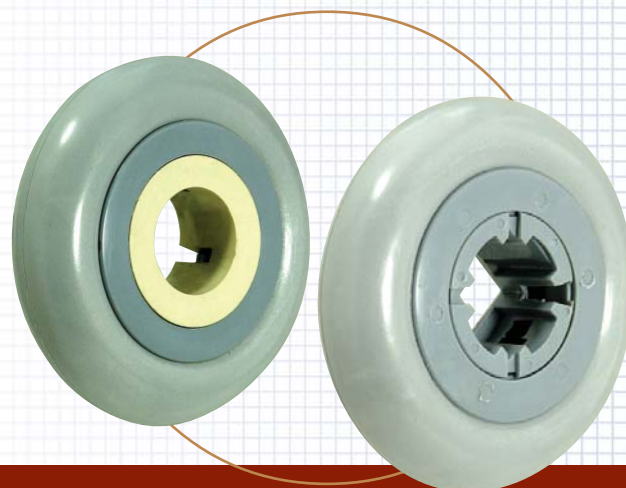

Wheel diameter (mm)	Outside diameter (mm)	Thread diameter (mm)	Tube size O.D. (mm)	Tube section	Tread width (mm)	Bore size (mm)	Length (mm)	Depth (mm)	Code
---------------------	-----------------------	----------------------	---------------------	--------------	------------------	----------------	-------------	------------	------

BUFFER WHEELS

114	-	-	25.4	Round	29	-	27 (hub)	-	BUF1R
114	-	-	25.4	Square	29	-	27 (hub)	-	BUF1SQ

BEARINGS (2 RS)

42	-	-	-	-	20	-	12	BEARING6004
					17	-	14	BEARING6303
47	-	-	-	-	20	-	14	BEARING6204
					25	-	12	BEARING6005
52	-	-	-	-	20	-	15	BEARING6304
					25	-	15	BEARING6205

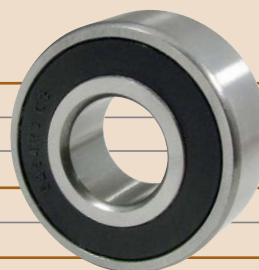

HEADED SPACERS

Bearing diameter (mm)	Axle bore (mm)	Bearing length (mm)	Collar thickness (mm)	Collar diameter (mm)	Code
15	10.2	15	10	20	TH15X10X10
15	10.2	15	5	20	TH15X5X10
15	12.2	23	9	20	TH15X9X12
20	10.2	25	1	25	TH20X1X10
20	10.2	20	5	25	TH20X5X10
20	12.2	20	2	25	TH20X2X12
20	12.2	20	5	25	TH20X5X12
20	12.2	20	11	25	TH20X11X12
25	12.2	29	1.5	30	TH25X2X12
25	12.2	29	8	30	TH25X8X12
25	16.5	29	3	30	TH25X3X16
30	16.5	40	5	30	TH30X5X16
30	21	40	5	40	TH30X5X20
30	21	40	10	40	TH30X10X20
50	31	48	5	60	TH50X5X30

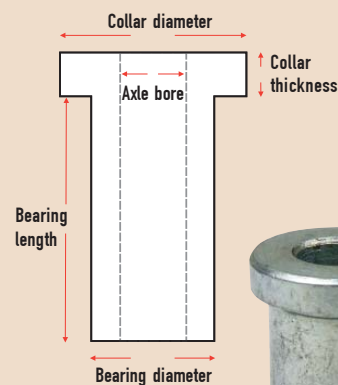

TERMS & CONDITIONS OF SALE

1. SETTLEMENT TERMS. Accounts are strictly nett with payment to be received on or before the twenty-first day of the month following despatch of goods. Credit accounts are opened subject to approved references.

2. CARRIAGE IS EXTRA.

3. RISK AND TITLE. The legal title in all goods supplied remains with us as long as there is any indebtedness in respect of any transaction whatsoever and whenever arising. The customer shall only be at liberty to sell the goods purchased from the Company prior to the passing of title on the understanding that if the customer does sell the goods then the customer will hold on trust for the Company so much of the proceeds of sale received by the customer under contracts which include any of the goods hereby sold either in their original or altered state as necessary to discharge payment in full to the Company.

4. CANCELLATIONS cannot be accepted for goods requiring special manufacture or modification. Goods may only be returned after written agreement by us.

5. TELEPHONE/VERBAL ORDERS. All confirmation orders received and not so marked shall be treated as new orders and if returned with our permission will be subject to a 15% handling charge. This action is regretted but essential to enable us to maintain a competitive price structure.

6. MINIMUM ORDER VALUE IS £20 UNLESS COLLECTED FOR CASH.

7. ALL PRICES QUOTED ARE SUBJECT TO VAT.

8. DESPATCH/DELIVERY. Although we make every effort to maintain sufficient stocks to be able to despatch ex-stock, our listing or accepting orders does not imply this obligation. Due to fluctuation in demand we shall not be liable to make good any loss or damage whether arising directly or indirectly out of delay in delivery. Goods are at Buyers risk from delivery.

9. SHORTAGES must be advised within 3 days receipt of goods otherwise we cannot accept claims.

10. NON-DELIVERY. We must be advised within 7 days of receipt of invoice otherwise claims cannot be accepted.

11. PRICES & SPECIFICATIONS. All quotations and specifications are subject to alteration and to withdrawal without notice. While every effort will be made to maintain prices as quoted, we can only accept orders at prices ruling at time of despatch. If the quantity ordered is less than that for which we quoted, we reserve the right to requote. All recommendations and specifications are given to the best of knowledge and ability, but we cannot accept any liability which may arise from their application.

12. ILLUSTRATIONS ETC. All illustrations, drawings etc. accompanying or referred to in our quotations or contained in our catalogue, price lists, or advertisements must be regarded as approximate representations only except where otherwise specified and are not binding in detail unless stated so to be in our quotations. All weights, measurements, performance, capacities and other particulars of the goods stated by us are stated in good faith as being approximately correct, but do not form any part of the contract and shall not be made the basis of any claims against us. We reserve the right to withdraw, add to and alter any standard types in our range, and to alter the prices and terms thereof, and do not undertake to carry stock of obsolete parts for more than a limited period. We make no warranty for the suitability of a product for a particular purpose.

13. DEFECTIVE PRODUCTS. We will credit/replace any products which we agree are defective and not due to misuse within six months from date of despatch, but we cannot accept liability for expenses incurred by customers on such defective products or for any direct or consequential damage arising from such defect. Misuse i.e. utilization of wheels and castors for purpose other than specified as intended use is for example if:

- a) Wheels and castors are used with higher load capacities than those specified in the catalogue.
- b) The objects are used on unsuitable, uneven floors.
- c) The ambient temperatures are too high or too low.
- d) The objects are moved by force with the wheels locked.
- e) The objects are exposed to particularly aggressive substances.
- f) The objects are subjected to improper rough impact and shock loads.
- g) Foreign matter may intrude into the tyres.
- h) Wheels and castors are used at excessive speeds.
- i) Modifications not approved by the manufacturer.

14. ALL ERRORS AND OMISSIONS EXCEPTED.



BIL can handle your handling requirements too

Aluminium modular hand and sack trucks, trolleys, carts, moving equipment and **SKOOTTS**[®]



BIL Materials Handling Division supply a range of product handling equipment that has satisfied the needs of our customers for over thirty years. We are the preferred supplier to many companies throughout the UK and are proud of our reputation as a manufacturer of innovative, quality solutions to meet the productivity and health and safety requirements of our customers.

Phone us for more information on 01249 822 222 or browse www.bilgroup.eu

Materials handling from





BIL CASTORS & WHEELS DIVISION

With our comprehensive range over 10,000 different types of castors, wheels and rollers, plus plant and machinery handling equipment that are manufactured by our parent company, we are confident that we can supply you with a product to match your specific requirements promptly, at a competitive price.

Our current stock holding of components and finished goods at our European Storage, Assembly and Distribution facility based in Calne, UK is valued at over £2 million.

Tried and tested, BIL is a brand that you can rely on for quality, innovation and service.

Call our sales team today to find out more!

BIL CASTORS & WHEELS

A division of Baz-Roll International Ltd

Porte Marsh Road

Calne

Wiltshire

SN11 9BW

Tel: +44 (0)1249 822222

Fax: +44 (0)1249 822300

Email: sales@bilgroup.eu

Web: www.bilgroup.eu

